

## INTEGRATED AM/FM RADIO RECEIVER CIRCUIT

The TBA570A is for use in small low-cost a. m. portable receivers as well as in high quality battery or mains-fed a. m. and a. m./f. m. receivers. The IC incorporates: a. m. mixer, oscillator, i. f. amplifier, a. g. c. amplifier, a. m. detector and capacitor, f. m./i. f. limiting amplifier and stable base bias for f. m. front-end, and an audio preamplifier and driver. The unique integrated audio part has an internally limited bandwidth (18 kHz) and negligible h. f. radiation back to the ferrite rod. This makes the TBA570A ideally suitable for small size a. m. receivers because print layout is not critical. The driver stage can directly drive complementary output stages ( $P_O = 6 \text{ W max.}$ ), or operate as a post amplifier ( $V_O = 500 \text{ mV}$ ). In its standard applications, the TBA570A can replace the TBA570.

QUICK REFERENCE DATA			
Applicable supply voltage range of receiver	$V_P$	2, 7 to 18	V
Ambient temperature	$T_{amb}$	25	$^{\circ}\text{C}$
Supply voltage at pin 8	$V_{8-16}$	nom. 5.3	V
-----			
Total quiescent current except output stages, driver stage TR30 and f. m. front-end	$I_{tot}$	typ. 9	mA
<b>A.M. performance (at pin 2)</b>			
R. F. input voltage: S/N = 26 dB for $P_O = 50 \text{ mW}$ (adjustable)	$V_i$	typ. 18	$\mu\text{V}$
	$V_i$	typ. 2	$\mu\text{V}$
A. G. C. range; change of r. f. input voltage for 10 dB expansion in audio range		typ. 65	dB
R. F. signal handling: $d_{tot} = 10\%$ ; $m = 0, 8$		typ. 150	mV
<b>F.M. performance (at pin 2)</b>			
R. F. input voltage; 3 dB before limiting	$V_i$	typ. 50	$\mu\text{V}$
<b>Audio performance</b>			
Output driver current (peak value)	$I_{11M}$	< 100	mA
Input impedance (at pin 12)	$ Z_{12-16} $	typ. 100	$\text{k}\Omega$

### PACKAGE OUTLINES

TBA570A : 16-lead DIL; plastic (SOT-38).  
TBA570AQ: 16-lead QIL; plastic (SOT-58).



CIRCUIT DIAGRAM

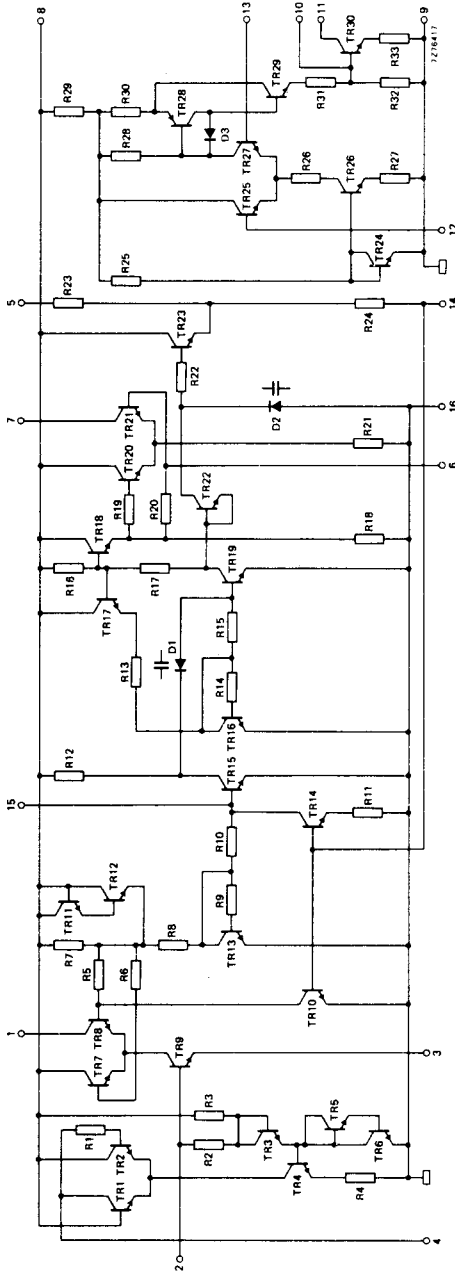

66

**RATINGS** Limiting values in accordance with the Absolute Maximum System (IEC 134)

Pin 11 voltage	$V_{11-9}$	max.	18	V
Pin 8 voltage	$V_{8-16}$	max.	8	V
Pin 11 current (peak value)	$I_{11M}$	max.	100	mA
Total power dissipation	see derating curve below			
Storage temperature	$T_{stg}$		-55 to +125	°C
Operating ambient temperature: $V_{8;4;7;1-16} = 8$ V; $I_{11M} = 100$ mA; see also derating curve below	$T_{amb}$		-20 to +85	°C

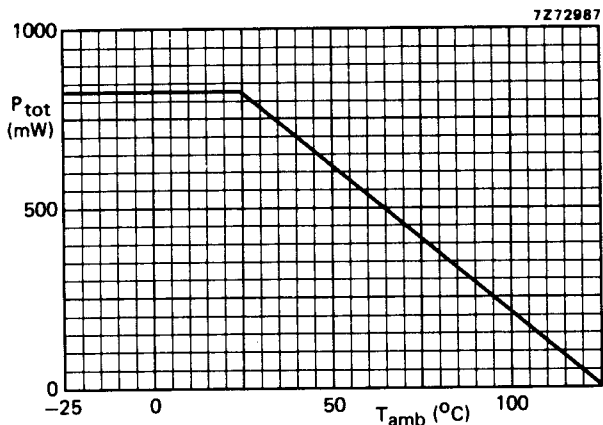

**DESIGN DATA**

Characteristics of integrated components are determined by process and layout data.

Pins not under measuring condition should not be connected.

Voltages with respect to pin 9 and 16 (tolerated minimum: 0 V)

Pins 1 and 7	$V_{1-9(16)}$ $V_{7-9(16)}$	} max.	18	V
Pin 4	$V_{4-9(16)}$			
Pin 8	$V_{8-9(16)}$	max.	8	V
Pin 3	$V_{3-9(16)}$	max.	3	V
Pin 5	$V_{5-9(16)}$	max.	4	V
Pin 14	$V_{14-9(16)}$	max.	1	V

Currents (tolerated minimum: 0 mA)

Pins 2, 6, 12, 13 and 15	$I_2; I_6; I_{12}$ $I_{13}; I_{15}$	} max.	80	μA
Pin 10	$I_{10}$			

**D.C. CHARACTERISTICS** at  $T_{amb} = 25\text{ }^{\circ}\text{C}$

Saturation voltage of driver stage

$I_C = 50\text{ mA}; I_B = 2,5\text{ mA}$

$V_{11-16sat}$	typ.	1,0 V
	<	1,5 V

Collector breakdown voltage of driver stage

$I_C = 25\text{ mA}; R_{BE} = 7\text{ k}\Omega$

$V_{11-16(BR)}$	>	18 V
-----------------	---	------

D.C. current gain of driver stage

$I_C = 50\text{ mA}$

$h_{FE}$	>	25
----------	---	----

Total quiescent current

except driver stage collector current;

f. m. front-end;

discrete output stages:  $V_{8-16} = 5,3\text{ V}$

$V_{8-16} = 4,2\text{ V}$

$I_{tot}$	typ.	9 mA
$I_{tot}$	typ.	8 mA

Applicable supply voltage range of receiver

$V_p$		2,7 to 18 V <sup>1)</sup>
-------	--	---------------------------

Base bias voltage for f. m. front-end

total external load current at pin 2:  $-I_2 = 150\mu\text{A}$

$V_{2-16}$	typ.	1,2 V
------------	------	-------

**A.C. CHARACTERISTICS** at  $T_{amb} = 25\text{ }^{\circ}\text{C}; V_{8-16} = 5,3\text{ V}; I_E (TR9) = 1\text{ mA}$

			0,45	1	10,7	MHz
Input conductance at pin 2	$g_{ie}$	typ.	-	0,4	0,5	mA/V
Output conductance at pin 1	$g_{oe}$	typ.	6	-	90	$\mu\text{A/V}$
Input conductance at pin 15	$g_{ic}$	typ.	0,35	-	0,7	mA/V

<sup>1)</sup> Adjustable by a dropping resistor in the  $V_p$ -line; see also maximum tolerated voltages for pins 1, 4, 7 and 8 in design data on page 3.



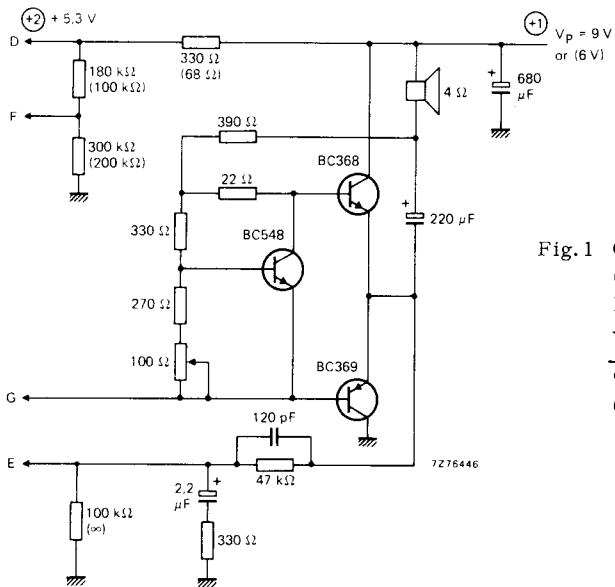

Fig. 1 Output stage for  $V_p = 9\text{ V}$  or  $6\text{ V}$  (resistor values between parentheses).

$V_p$	$R_L$	$P_o$ at $d_{tot} = 10\%$
9 V	4 Ω	1,8 W
6 V	4 Ω	0,6 W

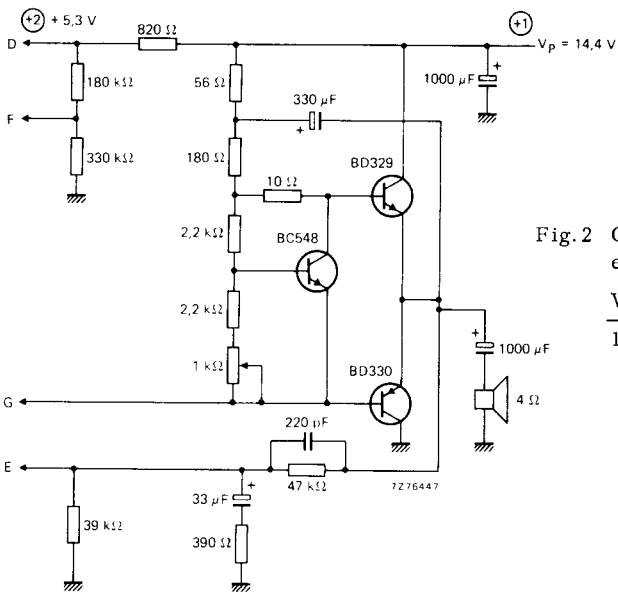

Fig. 2 Output stage for  $V_p = 14,4\text{ V}$ ; especially used in car radios.

$V_p$	$R_L$	$P_o$ at $d_{tot} = 10\%$
14.4 V	4 Ω	5,5 W

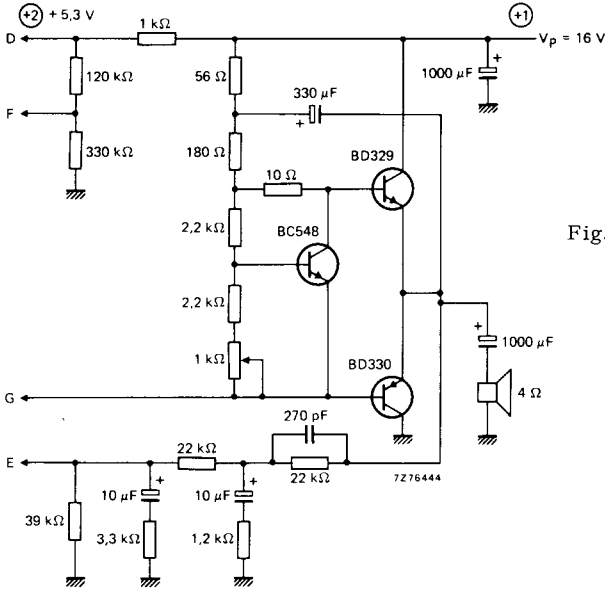

Fig. 3 Output stage for  $V_p = 16\text{ V}$ .

$V_p$	$R_L$	$P_o$ at $d_{tot} = 10\%$
16 V	4 Ω	6, 8 W

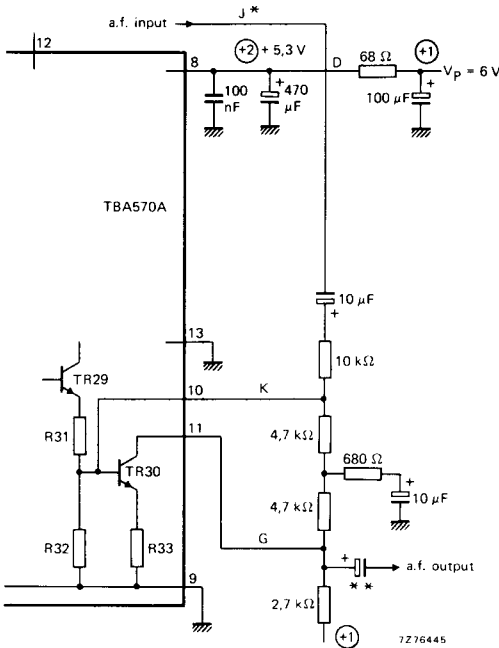

Fig. 4 Post amplifier for  $V_o = 500\text{ mV}$  and  $V_p = 6\text{ V}$ .

\*In circuit on page 5 volume control resistor (100 kΩ) and capacitor (100 nF) on pin 12 should be omitted.

\*\* Capacitor value depends on load.

**COIL DATA** (in circuit on page 5)

**High quality AM/FM receiver** (for portable and mains-fed applications)

A. M. -I. F. coils ( $f_0 = 455 \text{ kHz}$ )

I. F. bandpass filter :

- L9**  $N1 = 284, 5 \mu\text{H}$      **L10**  $N1 = 680 \mu\text{H}$   
 $Q_0 = 100$                        $Q_0 = 100$   
 $N1/N2 = 40$                        $N2/N1 = 74$   
 $N2/N3 = 1$                        $(N2 + N1)/N3 = 10, 7$   
 $|Z_T| = 3 \text{ k}\Omega$



F. M. -I. F. coils ( $f_0 = 10, 7 \text{ MHz}$ )

Second i. f. bandpass filter :

Ratio detector :

- L7**  $N1 + N2 = 2, 7 \mu\text{H}$      **L8**  $N1 = 2, 7 \mu\text{H}$      **L11**  $N1 = 2, 7 \mu\text{H}$      **L12**  $N2 + N3 = 3, 25 \mu\text{H}$   
 $Q_0 = 100$                        $Q_0 = 90$                        $Q_0 = 85$                        $Q_0 = 85$   
 $kQ_{L6-L7} = 1, 2$                        $N1/N2 = 5, 5$                        $kQ_{L11-L12} = 0, 7$                        $(N2 + N3)/N1 = 6$   
 $N1/N2 = 1, 75$                        $N1/N2 = 2, 2$                        $N2 = N3$

**Low-cost 2-band AM portable receiver** (see page 9)

- L1**   $N1 = 11$      **L2**   $N1 = 60$      **L1 and L2 on ferrite rod; 10 mmØ; length = 10 cm**  
 $N2 = 2$                        $N2 = 4$   
 wire : 1, 1 Ø                      wire : 20 x 0, 03

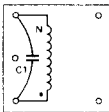
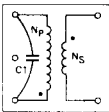
- L3**   $N = 284, 5 \mu\text{H}$       $f_m = 452 \text{ kHz}$      **L4**   $N_p = 284, 5 \mu\text{H}$       $f_m = 452 \text{ kHz}$   
 $C1 = 430 \text{ pF}$       $Q_0 = 100$                        $N_p/N_s = 16, 7$       $Q_0 = 100$   
 wire : 0, 1 Ø                      wire : 0, 1 Ø  
 core material : 7 MN(C)                      core material : 7 MN(C)

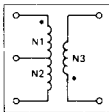
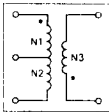
- L5**   $N1 + N2 = 127 \mu\text{H}$       $f_m = 1 \text{ MHz}$      **L6**   $N1 + N2 = 13 \mu\text{H}$       $f_m = 7 \text{ MHz}$   
 $(N1 + N2)/N2 = 58$       $Q_0 = 100$                        $(N1 + N2)/N2 = 20$       $Q_0 = 90$   
 $(N1 + N2)/N3 = 4, 8$       $C_p = 200 \text{ pF}$                        $(N1 + N2)/N3 = 4$       $C_p = 40 \text{ pF}$   
 wire : 0, 1 Ø                      wire : 0, 1 Ø  
 core material : 7 BR                      core material : 119 AM(C)

Note

In the circuit on page 9 for L3 and L4 a similar coil to L9 in the circuit on page 5 can be used with the following exceptions :

L3 : secondary windings N2 and N3 are not used.

L4 : secondary windings N2 and N3 are connected in series.

When using a resistor between pins 2 and 15 (see dashed resistor in circuit on page 9), signal handling is improved.



Low-cost 2-band (SW-MW) AM portable receiver ( $P_O = 250 \text{ mW}$ )

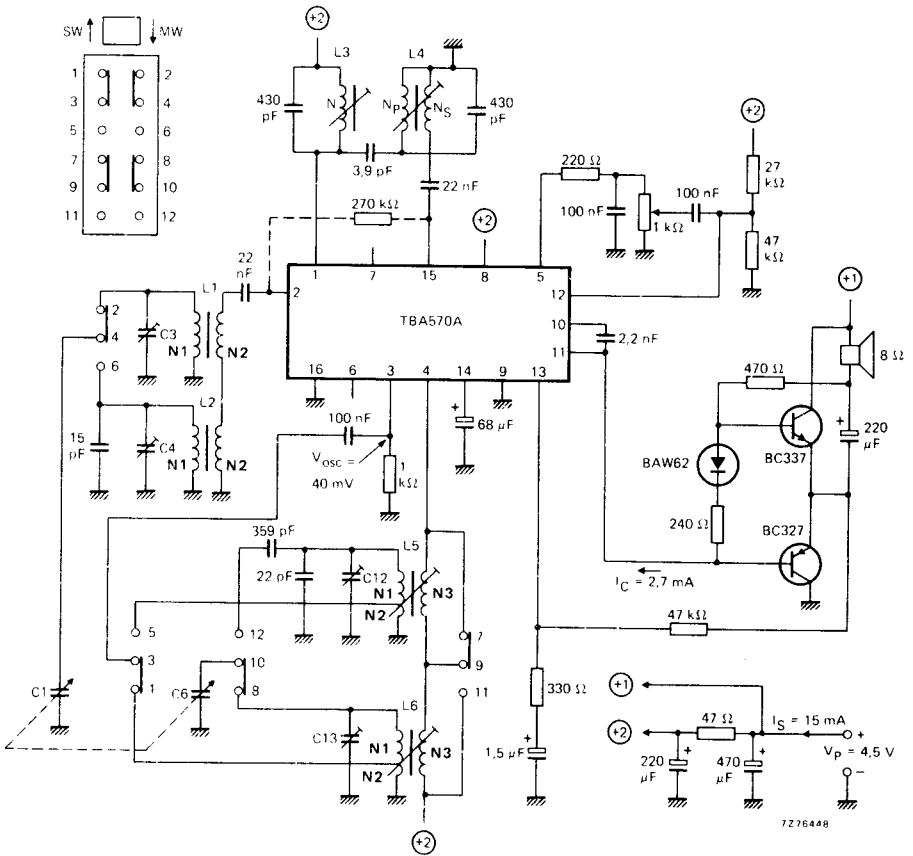

7276488

Note: C1 and C6 max. 385 pF.

APPLICATION INFORMATION at  $T_{amb} = 25^{\circ}C$

A.M. performance	$V_{8-16}$	5, 3 V 1)	4, 2 V 2)
R.F. input voltage: $S/N = 26$ dB (notes 3 and 4) for $P_O = 50$ mW (adjustable); notes 3, 4 and 5	$V_i$	typ. 18	10 $\mu V$
	$V_j$	typ. 2	2 $\mu V$
R.F. input voltage for 10 mV (a.f.) across volume control (notes 3 and 4)	$V_i$	typ. 2, 7	4, 5 $\mu V$
A.F. voltage across volume control at 100 $\mu V$ (r.f.) input voltage (notes 3 and 4)	$V_O$	typ. 70	70 mV
Signal-to-noise ratio at 1 mV (r.f.) input voltage (notes 3 and 4)	S/N	typ. 46	47 dB
A.G.C. range (change in r.f. input voltage for 10 dB expansion in audio range); notes 3 and 4		typ. 60	60 dB
R.F. signal handling capability at 80% modulation; $d_{tot} < 10\%$ (note 3)	$V_i$	typ. 150	7 mV
Harmonic distortion of h.f. part over most of a.g.c. range; $m = 0, 3$ ; $f_m = 1$ kHz (note 6)	$d_{tot}$	typ. 1	1 %
I.F. selectivity	$S_9$	typ. 33	16 dB
I.F. bandwidth (3 dB)	B	typ. 5	5, 5 kHz

Notes

1. See circuits on pages 5, 6 and 7 (high quality AM/FM receiver).
2. See circuit on page 9 (low-cost 2-band AM portable receiver).
3. a. A.F. signal: measured across volume control.  
b. R.F. signal: measured at pin 2 with the aerial circuit connected (source resistance about 1  $k\Omega$ ).  
c.  $f_o = 1$  MHz;  $f_m = 1$  kHz.
4.  $m = 0, 3$ .
5. A.M. sensitivity for  $P_O = 50$  mW can be adjusted by means of the a.c. feedback network in the audio part e.g.:  $V_i = 1, 5 \mu V$  for  $P_O = 50$  mW ( $S/N \approx 4$  dB).
6. Distortion can be decreased to 0, 7% by connecting a resistor of 270  $k\Omega$  between pins 2 and 15.

**APPLICATION INFORMATION** (continued) at  $T_{amb} = 25\text{ }^{\circ}\text{C}$ ;  $V_{8-16} = 5,3\text{ V}$

Measured in the circuit on page 5

**F.M. performance**

Sensitivity for an f. m. signal 3 dB before limiting  
at  $75\text{ }\Omega$  aerial input of f. m. front-end (note 1)  
at pin 2; first i. f. (notes 2 and 6)

$V_i$	typ.	3,5	$\mu\text{V}$
$V_i$	typ.	50	$\mu\text{V}$

Sensitivity for 26 dB S/N ratio  
at  $75\text{ }\Omega$  aerial input of f. m. front-end (note 1)

$V_i$	typ.	2,5	$\mu\text{V}$
-------	------	-----	---------------

A. F. output voltage across volume control  
at an i. f. signal beyond limiting (note 2)

$V_o$	typ.	120	mV
-------	------	-----	----

Signal-to-noise ratio  
over most of signal range (note 2)

S/N	typ.	65	dB
-----	------	----	----

A. M. suppression over most of signal range (note 3)

	typ.	60	dB
--	------	----	----

I. F. selectivity (note 4)

$S_{300}$	typ.	43	dB
-----------	------	----	----

I. F. bandwidth (3 dB; note 4)

B	typ.	150	kHz
---	------	-----	-----

A. F. signal distortion  
3 dB before i. f. limiting (note 5)

$d_{tot}$	typ.	0,8	%
-----------	------	-----	---

Notes

1. Aerial e. m. f. ( $V_i$ ) at  $f_o = 98\text{ MHz}$ ;  $R_S = 50\text{ }\Omega$ ;  $\Delta f = \pm 22,5\text{ kHz}$ ;  $f_m = 1\text{ kHz}$ .
2.  $f_o = 10,7\text{ MHz}$ ;  $\Delta f = \pm 22,5\text{ kHz}$ ;  $f_m = 1\text{ kHz}$ .
3. A. M. signal:  $m = 0,3$ ;  $f_m = 1000\text{ Hz}$ .  
F. M. signal:  $f_o = 10,7\text{ MHz}$ ;  $\Delta f = \pm 75\text{ kHz}$ ;  $f_m = 400\text{ Hz}$ .  
Carrier simultaneously modulated with a. m. and f. m.
4. Including ratio detector.
5.  $f_o = 98\text{ MHz}$ ;  $\Delta f = \pm 40\text{ kHz}$ ;  $f_m = 1\text{ kHz}$ .
6. Pin 3 by-passed to ground with a capacitor of  $220\text{ nF}$ .

**AUDIO PERFORMANCE**

Distortion before clipping (note 1)	$d_{tot}$	typ.	0.5	%
Input impedance (note 2)	$ Z_i $	typ.	90	k $\Omega$
Noise output power: volume control at min. (note 3)	$P_n$	typ.	10	nW
Overall fidelity: flat within 3 dB (obtainable values)			35 Hz to 15	kHz
Open loop voltage gain	$G_v$	typ.	62	dB

$V_P$	V	4.5	6	9	14.4	16
$R_L$	$\Omega$	8	4	4	4	4
$P_O$ at $d_{tot} = 10\%$	W	0.22	0.6	1.8	5.5	6.8
$P_O$ at onset of clipping: $d_{tot} = 1\%$	W	0.15	0.4	1.2	4	4.8
$V_i$ for $d_{tot} = 10\%$ (pin 12)	mV	14	16	25	50	45
$V_i$ for $P_O = 50$ mW (pin 12)	mV	5.5	4.5	4	3.5	3.5
Output transistors		BC327 BC337	BC368 BC369	BC368 BC369	BD329 BD330	BD329 BD330
Circuit diagrams on page 6, 7 or 9		page 9	Fig. 1	Fig. 1	Fig. 2	Fig. 3

**Post-amplifier (see Fig. 4 on page 7)**

Output voltage : 500 mV  
 Audio gain (adjustable): 5  
 Distortion : 0.2%

Notes

1. Measured at 1 kHz and a negative feedback of 16 dB.
2. At the maximum tolerated value of resistance-tap/bleeder at pin 12.
3. Measured at a bandwidth of 60 Hz to 15 kHz, pin 12 being connected via a capacitor of 32  $\mu$ F to pin 9:  $R_L = 4 \Omega$ .



APPLICATION INFORMATION (continued)

Typical a.g.c. curves for AM reception (circuit diagram on page 5)

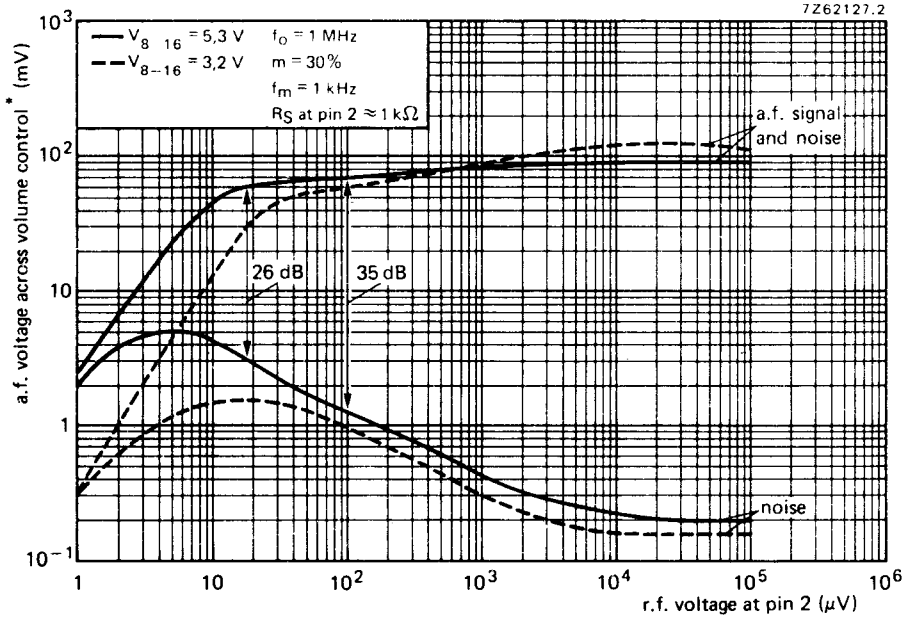

A.F. voltage across volume control as a function of r.f. voltage at pin 2.

\*) Slider at lower end.

APPLICATION INFORMATION (continued)

Typical S/N curves for FM reception (circuit diagram on page 5)

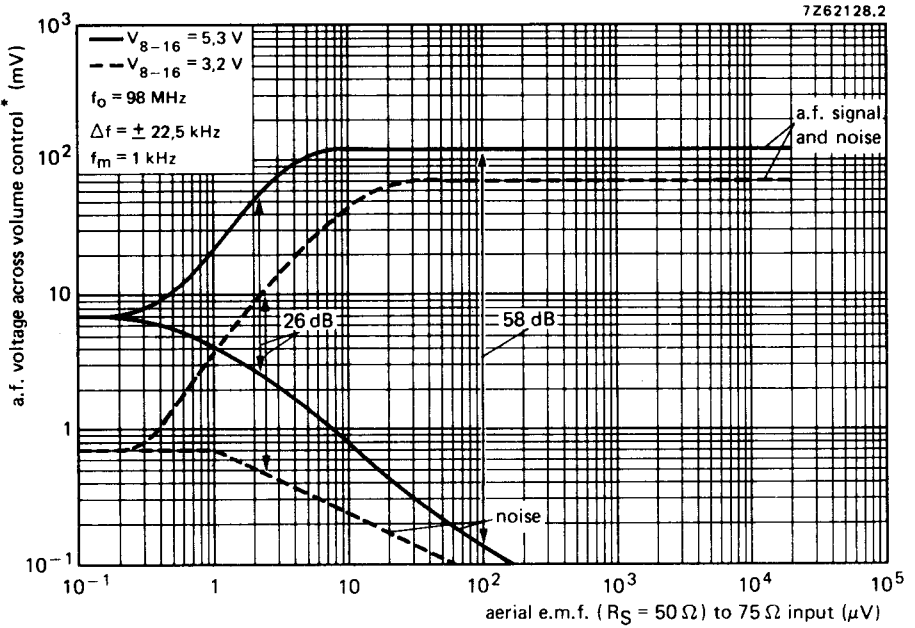

A.F. voltage across volume control as a function of aerial e. m. f. from a source with  $R_S = 50 \Omega$  to the  $75 \Omega$  input of the f. m. front-end.

\*) Slider at lower end.